



AMU2-8HD+ & 3G
Audio Monitoring
Units

Handbook

TSL

Vanwall Road, Maidenhead, Berkshire, SL6 4UB
Telephone +44 (0)1628 676200, FAX +44 (0)1628 676299

SAFETY

Installation.

Unless otherwise stated TSL equipment may be installed at any angle or position within an operating temperature range of 5° - 30° C .

All TSL equipment conforms to the EC Low Voltage Directive:

EC Low Voltage Directive (73/23/EEC)(OJ L76 26.3.73)(LVD). Amendment: (93/68/EEC) (OJ L220 30.8.93).

The earth pin on the IEC mains inlet connector is connected to the metal frame of the equipment, to 0 volts on the internal DC PSU and to signal ground, unless otherwise stated. All metal panels are bonded together.

In all cases, the frame of the equipment must be earthed on installation.

Due consideration for cooling requirements must be given when mounting the equipment. Ideally 1RU of rack space should be left above and below the unit.

Check that the fuse rating is correct for the local power (mains) supply. Replacement fuses must be of the same rating and type for continued protection against fire risk.

Do not switch on until all connections are made.

WARRANTY, MAINTENANCE AND REPAIR

All TSL equipment is guaranteed for one year from the date of delivery to the customer's premises. If the equipment is to be stored for a significant period, please contact TSL concerning a possible extended warranty period.

Failure during warranty

If any TSL product should fail or become faulty within the warranty period, first please check the PSU fuses.

All maintenance work must be carried out by trained and competent personnel.

Technical support information

E-Mail address: support@televisionssystemsltd.uk

Telephone Support Number for the UK and Europe: +44 (0) 1628 670000

Telephone Support Number for the USA only: 1 877 591 2108

TSL Returns Procedure

Please telephone +44(0)1628 676200 (Fax: +44 (0)1682 676299) and ask for Production Sales who will provide a Returns Number. This will enable us to track the unit effectively and will provide some information prior to the unit arriving.

For each item, this unique Returns Number must be included with the Fault Report sent with the unit.

A contact name and telephone number are also required with the Fault Report sent with the unit.

Fault report details required.

- Company:
- Name:
- Address:
- Contact Name:
- Telephone No:
- Returns Number:
- Symptoms of the fault (to include switch setting positions, input signals etc):

Packing

Please ensure that the unit is well packed as all mechanical damage is chargeable. TSL recommends that you insure your equipment for transit damage.

The original packaging, when available, should always be used when returning equipment..

If returned equipment is received in a damaged condition, the damage should be reported both to TSL and the carrier immediately.

Contents

- 1.0 Introduction
- 2.0 Front Panel Controls
 - 2.1 Input and Meter Selection Buttons
 - 2.2 Output Switching and monitoring
- 3.0 Pin-out Details
 - 3.1 Line output
 - 3.2 Analogue Output Connector – D25 Socket Pinout
 - 3.3 AES Input/Output connector – D25 Socket Pinout
 - 3.4 Control Connector - D9 Socket
 - 3.5 External Connector - D15 Plug
 - 3.6 S/HD BNC connectors
 - 3.7 Re clocked BNC connector
 - 3.8 Down converted BNC connector
 - 3.9 Remote Control Connector/ RS 422 - D9 Socket
 - 3.10 Aux (Dolby Metadata) - D9 Socket
- 4.0 LS Output
- 5.0 Configuration Switch Functions
- 6.0 General Notes
- 7.0 Specification
- 8.0 Block schematic diagram
- 9.0 Front and Rear panel layout drawings.

AMU2-8HD+/3G AUDIO MONITORING UNIT

1.0 Introduction

This handbook covers the AMU2-8HD+ and AMU2-8HD-3G Audio Monitoring Units.

The AMU2-8HD+/3G are full rack 2RU x 310mm deep Audio Monitoring Units with eight TSL 53 segment bargraphs.

The following features are standard:

- Four AES/EBU inputs.
- Two HD/SDV auto sensing inputs.
- Re clocked output of input.
- Two Stereo analogue inputs.
- Phase reverse switch.
- Out-of-phase error indication.
- Down converted video or SDV output
- Additive output switch selection.
- Composite output.
- Headphone outputs with LS muting.
- Fixed and variable stereo line outputs of selected pair.
- Four simultaneous line outputs.
- Dolby compatible D and E.
- Metadata display.
- EBU digital, UK PPM and EBU PPM scales available.
- Internal amplifier.
- 1080p50 / 1080p/60 capable (3G units only)

2.0 Front Panel Controls

2.1 Input and Meter Selection Buttons

AES1, 2, 3 & 4	AES input. This is selected by first pressing the AES select button, then selecting A(1/2),B(3/4), C(5/6), D(7/8) respectively on the LS monitoring panel.
Analogue 1 & 2	These inputs are selected by pressing the Phase Reverse/function button and then the AES/ANLG button on the input select panel. The signals are displayed on bargraph A (1/2) and B (3/4).
S/HD (Auto sensing)	This is selected by pressing the S/HD button 1 or 2 and then selecting GP1 to GP4. The de-embedded SDV or HD is then displayed on the bargraphs A(1/2),B(3/4), C(5/6), D(7/8) respectively. Selecting e.g. group 1 and 2 together allows all eight channels to be monitored.
Dolby	Encoded Dolby can either be carried on an AES bit stream or as embedded HD or SD. To select the Dolby function press the DOLBY button after selecting either AES or S/HD buttons. If a valid Dolby signal is present the Dolby button will illuminate steady red. If a Dolby signal is not present or is lost the button will flash. To select one pair from one group containing two Dolby signals on each pair, select the group (1, 2, 3 or 4) from the H/SDV input and then either A, B, C, or D from the input selector to choose the pair.
Letterbox	Shows the composite output as 16:9 aspect ratio on a 4:3 monitor.
Ø Rev (Function)	Momentary phase reverse between A1 and A2 outputs.
Brightness	To increase the brightness of the bargraph display Press phase reverse and monitoring select A. To decrease the Brightness press phase reverse and monitoring select B.
Reference Marker	To turn the reference marker on and off press phase Reverse and the CUT button.

Meta Data Display

This window indicates:
Channel coding (Rate/non PCM/Dolby D/Dolby)
Channel format (e.g. 8x1/2+2+2+2 etc)
Digital peak read out of selected pair.
Dialogue normalisation value where set

N.B. To reset/refresh display press Phase Reverse then Dolby select switches simultaneously.

2.2 Output Switching and monitoring

A, B, C & D

These buttons select the audio from pairs 1/2 (A) through to 7/8 (D)
The buttons toggle. Additive mixing is possible if two or more buttons are selected together and are fed only to the variable line outputs.

ALL

Enables multi-channel listening on variable outputs. When selected, multichannel variable outputs are enabled and full surround can be monitored.
Selecting ALL, holding down and pressing output selection A or B will toggle between using ABC for discrete 5.1 or BCD for discrete 5.1.

L

Enables the left hand channel to be monitored by both outputs.

R

Enables the right hand channel to be monitored by both outputs.

M

A mono signal of the left and right hand channels is applied to both outputs.

Lt Rt

Allows a multi channel signal to be monitored and is a stereo 'down mix' of a Dolby decoded signal. (Mutes multi channel outputs)

5.1

Enables/Disables 5.1 metadata dynamic range control.

Dim

Approximately 16dB of attenuation is switched into the audio path.

Cut/Mute

The front panel button Cut(s) the signal to all Variable O/Ps.

Volume

The loudspeaker, headphone and variable O/P's may be varied.

3.0 Pin-out Details

3.1 Line output

XLRS	PIN	FUNCTION
ANALOG 1	1	GND
ANALOG 1	2	1 IN+
ANALOG 1	3	1 IN-
ANALOG 2	1	GND
ANALOG 2	2	2 IN+
ANALOG 2	3	2 IN-

3.2 D25 Socket, Analogue output connector

D 25 SOCKET ON AMU	AUDIO OUTPUTS
PIN NO	FUNCTION
1	A8+ (7.1)
14	A8- (7.1)
2	Ground
15	A7+ (7.1)
3	A7- (7.1)
16	Ground
4	A6+ (RS)
17	A6- (RS)
5	Ground
18	A5+ (LS)
6	A5- (LS)
19	Ground
7	A4+ (LFE)
20	A4- (LFE)
8	Ground
21	A3+ (Centre)
9	A3- (Centre)
22	Ground
10	A2+ (FR)
23	A2- (FR)
11	Ground
24	A1+ (FL)
12	A1- (FL)
25	Ground
13	N/C

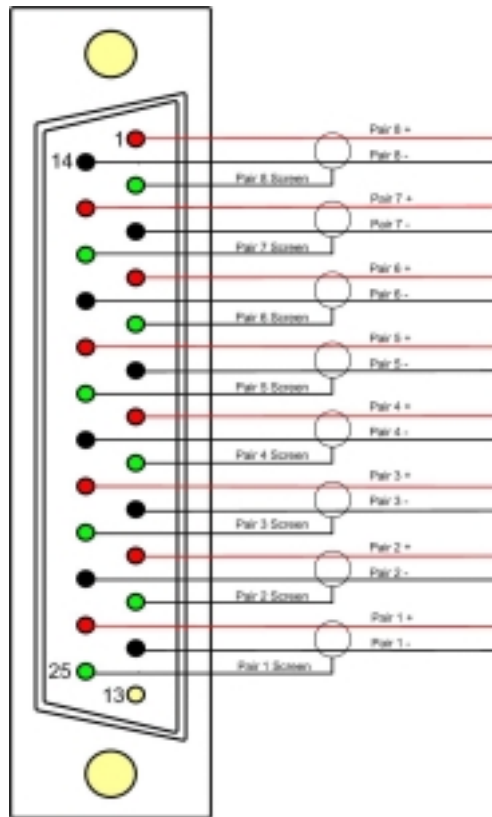

3.5 External Connector – D15 Plug

D15 PIN	EXTERNAL FUNCTION
1	Dim
2	Cut
3	GPI
4	Cut
5	Lt Rt enable
6	GPI
7	N/C
8	N/C
9	N/C
10	N/C
11	N/C
12	N/C
13	N/C
14	+5V
15	0V

3.6 S/HD connectors

This input auto detects HD or SDV signals.

3.7 Re clocked connector

This connector gives a re clocked output of the selected H/SDI input signal.

3.8 Video output connector

This gives a down converted output of HD (Vision only) or a composite PAL/NTSC video. N.B. This is dependant on the switch selection detailed in section 5.

3.9 Remote Control Connector/ RS 422 - D9 Socket

This is wired for RS422.

D9	CONTROL
1	0V
6	0V
2	TX-
7	TX+
3	RX+
8	RX-
4	0V
9	0V
5	N/C

3.10 Aux (Dolby Metadata) - D9 Socket

This is wired for RS422.

D9	CONTROL
1	0V
6	0V
2	TX-
7	TX+
3	RX+
8	RX-
4	0V
9	0V
5	N/C

4.0 LS Output

This is a single ended amplifier therefore one side may be connected to ground.

5.0 Configuration Switch Functions (z12a.hex/z13.mcs FPGA)
ACI code 7.03 (Note:Subject to change)

SWITCH SECTION	FUNCTION
1	N/U
2	N/U
3	Loudspeaker O/P mute - UP
4	D25 Anlg variable – Up/Fixed - Dwn
5	AES variable –Up/Fixed -Dwn
6**	XLR line O/P's fixed – Up/variable-Dwn
7	Lo Ro-Up/Lt Rt-Dwn
8	Comp out-Up/ SDI - Dwn

** This output on the first pair of the D25 – Analogue output connector.

Note: The calibration, Frame delay (In Dolby mode) and scale type are factory set.

6.0 Notes

0 dBm = 0.775V into 600Ω i.e. 1mW power dissipation.

0 dBu = 0.775V rms = PPM 4.

Nominally, -18 dB ref 0FS = 0 dBu output.

European line up: -18 dBu

American lineup: -20 dBu

Please note that some American equipment has the function of the XLR pins 2 & 3 reversed.

TSL product is wired to the European standard

The Dolby (CAT552) card can be reset by pressing the phase reverse and the Dolby select buttons simultaneously.

The screw locks on the D25 connectors use UNC 4-40 standard threads.

6.1 One frame Delay in Dolby mode option.

This operates on the down converted output only.

7.0 AMU2-8HD+/3G Technical Specifications

Power Supply

Supply Voltage	100 -240V AC @ 50Hz/60Hz +/- 10%
Power Consumption	60 Watts.
	Or
Supply Voltage	12V DC

Physical Dimensions

Height	88mm (2RU)
Width	483mm (19")
Depth	280mm
Weight	3500gm

Input 1 and 2

Connector Type	XLR 3 pin. Pin 1 Gnd, Pin 2 hot, Pin 3 cold.
Signal	Balanced line level audio.
Frequency Response	30Hz to 25kHz
Impedance	>20kΩ

Inputs AES 1, AES 2

Connector Type	XLR (F) 3 pin. Pin 1 Gnd, Pin 2 hot, Pin 3 co
Standard	AES3 (1994) 32, 44.1, 48, 96 KHz
Impedance	Balanced 110 Ohm.

Inputs AES 1, 2, 3 and 4

Connector type	D25
Standard	AES3 (1994) 32, 44.1, 48, 96 KHz
Impedance	Balanced 110 Ohm.

Inputs, HD/SDV (auto sensing)

Connector Type	BNC.
Standard	SMPTE 259M 4:2:2 component 525/60 or 625/50 with embedded 48kHz audio. HDS DI (SMPTE 292M) – 720P & 1080i @ 50, 59.94 & 60Hz (1080p @ 50/59.94/60Hz where applicable)
Impedance	75ohm
Return Loss	<-20dB to 1.5GHz (3GHz TBA)

AUX (Metadata Output)

Connector	D9 (RS422)
-----------	------------

Remote Control

Connector	D9 (RS 422)
-----------	-------------

Setup

Flash card port. (Factory use only)

Dolby

Dolby Digital or Dolby E decoding from selected AES input or selected embedded audio.

Note: The Dolby (CAT522) card can be reset by pressing the phase reverse and the Dolby select buttons simultaneously.

Display indicates:

Channel coding
(rate/non pcm/dolby D/dolby)
Channel format (e.g. 8x1/2+2+2+2 etc)
Digital peak readout of selected pair.
Dial norm value where set**Down converted Output**

Return Loss

Better than -16.5dB to 1.5GHz

Connector

BNC

Note: This is a video monitoring point only.
This connector also gives re clocked SDV out when SDV is applied to the input.**Re clocked Output**

Return Loss

< -15dB up to 1.5GHz (3GHz TBA)

Connector

BNC

Line Output.

Connector

XLR 3 pin Male (variable line out A1 &A2)

Impedance

50Ω

Output Levels

Through level control with 12dB gain.

Connector

D25

Impedance

>20kΩ

Output Levels

Fixed (+ and – 1dB) and Variable (12dB gain).

Noise

Better than -70 dB (22Hz to 22 KHz)

Headphone Output.

Connector

Stereo Jack socket type A

Impedance

50Ω

Output Levels

Through level control with 0dB gain.

Loudspeaker Outputs.

Connectors

4mm Binding Posts

Output rating

Max 15W /Ch into 4Ω,

HD Standards Supported

1080p/50/59.94/60Hz (3G units only)
1080i/50
1080i/59.94
1080i/60
720p/50
720p/59.94
720p/60

8.0 Block schematic Diagram



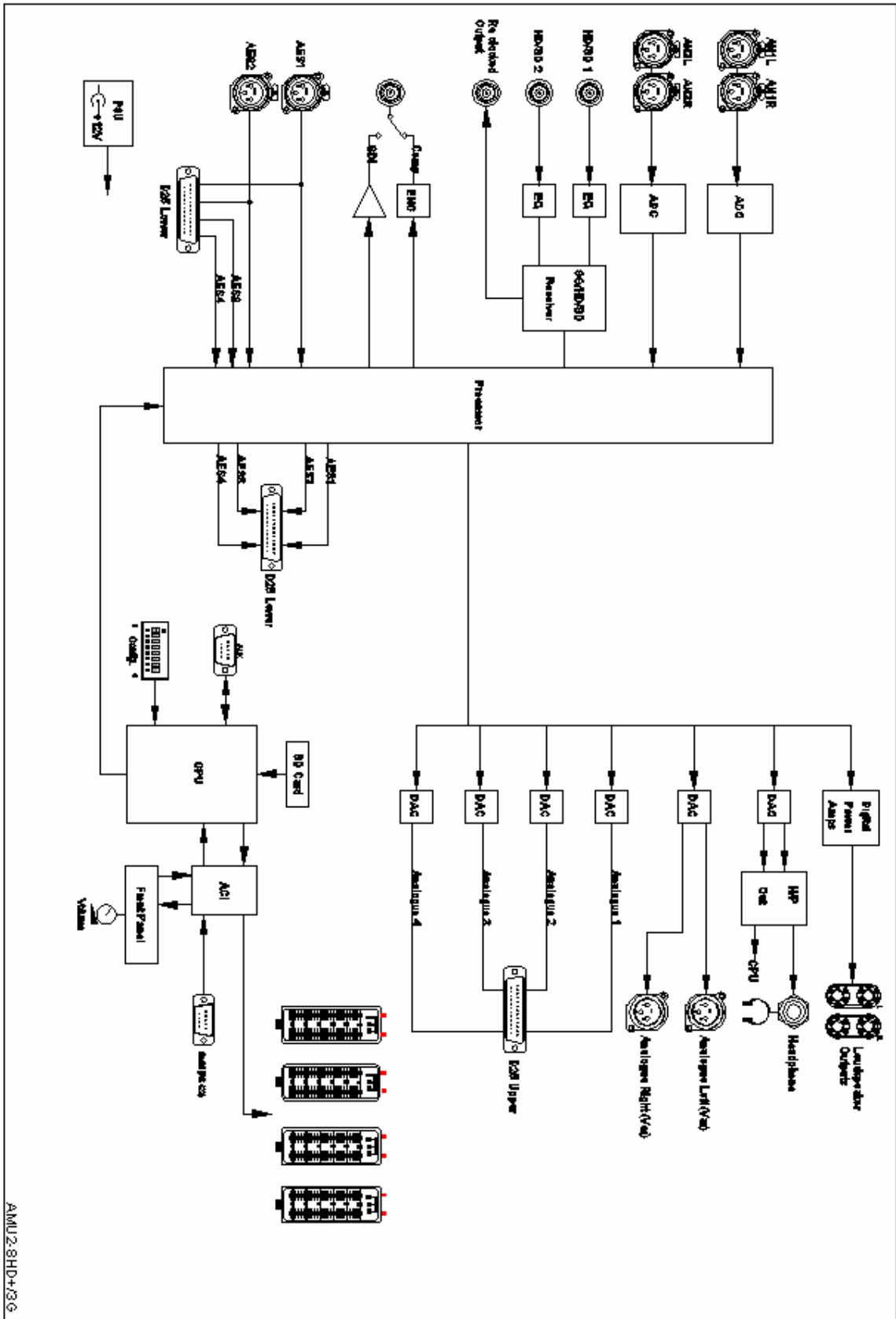

9.0 Front and rear Panel layouts

